



## Motor Driven Industrial Siren

*Heavy Duty, Outdoor*

### 315A-AH

#### FEATURES

- > Fully enclosed motor
- > Weatherproof
- > Adjustable siren direction
- > AC or DC operation

#### AGENCY APPROVALS

- > UL Listed for continuous duty

#### SPECIFICATIONS

- > 2.5 amp motor
- > Heavy gauge aluminum construction
- > Frequency 1100 Hz

Heavy duty, industrial design, motor driven siren that emits a continuous loud piercing wail.

Mounts to any solid surface using two bolts. May be swiveled through 180°, vertically or horizontally, depending on orientation of bracket.

Used for initial installation and MRO applications in factories, lumber yards, security installations, and score boards.

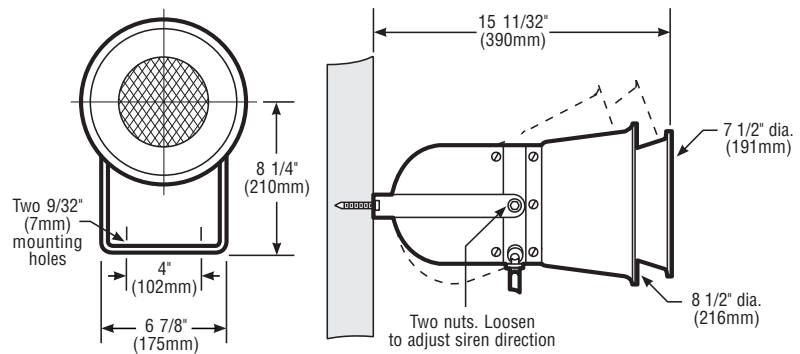

Cat. No.	Volts	Amps	V A	dB at 10 Ft.
315A-AH	120V AC/DC	2.5	300	110

D-04